



# ConnectCore MP15

Development Board

---

Hardware Reference Manual

## Revision history—90002511

Revision	Date	Description
1P	December 2022	Initial draft.
2P	March 2023	Added ESD section; added SOM height.
3P	July 2023	Revised features list, updating Power, Storage, and Communications sections; changed name of Ethernet PHY and added caution statement; revised Supply voltages section and table; removed height value from Mechanical specifications; fixed typos and minor formatting errors.
A	February 2024	Added USB OTG caution statement, rephrased boot modes statement in System boot topic.
B	June 2024	Swapped CAD1 and CAD2 connectors in table.
C	October 2025	Removed reversed polarity caution note from Gigabit Ethernet topic; modified the CAN, UART, and USB Host topics.

## Trademarks and copyright

Digi, Digi International, and the Digi logo are trademarks or registered trademarks in the United States and other countries worldwide. All other trademarks mentioned in this document are the property of their respective owners.

© 2022-2026 Digi International Inc. All rights reserved.

## Disclaimers

Information in this document is subject to change without notice and does not represent a commitment on the part of Digi International. Digi provides this document “as is,” without warranty of any kind, expressed or implied, including, but not limited to, the implied warranties of fitness or merchantability for a particular purpose. Digi may make improvements and/or changes in this manual or in the product(s) and/or the program(s) described in this manual at any time.

## Warranty

To view product warranty information, go to the following website:

[www.digi.com/howtobuy/terms](http://www.digi.com/howtobuy/terms)

## Customer support

**Gather support information:** Before contacting Digi technical support for help, gather the following information:

- Product name and model
- Product serial number (s)
- Firmware version
- Operating system/browser (if applicable)
- Logs (from time of reported issue)
- Trace (if possible)
- Description of issue
- Steps to reproduce

**Contact Digi technical support:** Digi offers multiple technical support plans and service packages. Contact us at +1 952.912.3444 or visit us at [www.digi.com/support](http://www.digi.com/support).

## Feedback

To provide feedback on this document, email your comments to

[techcomm@digi.com](mailto:techcomm@digi.com)

Include the document title and part number (ConnectCore MP15 DVK, 90002511 C) in the subject line of your email.

# Contents

---

## About the ConnectCore MP15 DVK

Features and functionality .....	6
Safety instructions .....	7
ESD .....	7
Block diagram .....	8
Placement .....	9
Top view .....	9
Bottom view .....	10
Connectors .....	10

## Interfaces

Power interfaces .....	13
DC-in jack connector .....	13
Coin cell connector .....	13
Power and reset buttons .....	14
System boot .....	14
Debug interfaces .....	14
JTAG .....	14
Console port .....	15
Multimedia .....	15
Parallel/LVDS display .....	15
MIPI/HDMI display .....	17
Parallel camera .....	18
Audio .....	19
Storage interface .....	20
MicroSD .....	20
Communication .....	20
Gigabit Ethernet .....	20
UART/RS-232/RS-485 .....	20
CAN .....	21
USB Host .....	22
USB OTG .....	23
Mini PCI Express slot .....	24
XBee socket .....	24
MikroBus socket .....	24
SPI and I2C .....	24
GPIO .....	24
User interfaces .....	25
Wireless .....	25

## Specifications

Electrical specification .....	26
Supply voltages .....	26
Mechanical specification .....	26
Environmental specification .....	26
WLAN specification .....	26

## About the ConnectCore MP15 DVK

---

The Digi ConnectCore MP15 wireless SOM kit is a complete development platform for intelligent, connected and secure embedded products with a broad suite of tools and turnkey Linux software support.

**Note** While the ConnectCore MP15 system-on-module is designed to be used in a production environment, the ConnectCore MP15 Development Kit is designed only for development and testing in a pre-production environment.

---

### Features and functionality

- ConnectCore MP15 module
  - STM32MP157C dual ARM Cortex-A7 and single Cortex-M4 cores operating at speeds up to 800 MHz
  - Up to 256 MB, 16-bit DDR3 memory
  - Up to 256 MB, 8-bit SLC NAND flash memory
  - IEEE 802.11 a/b/g/n/ac WLAN and Bluetooth 5.0
- Power
  - Power jack or industrial-dedicated 5V power connector
  - Coin-cell battery connector, supplying the on-board RTC
  - Power and reset buttons
- Boot source configuration
  - NAND, USB, microSD
- Debug
  - Standard IEEE 1149.1 JTAG interface
  - Serial console at AB-type micro-USB connector and TTL level
- Multimedia
  - MIPI DSI display
  - HDMI display (through MIPI-to-HDMI transceiver)
  - Parallel 24-bit LCD interface with FFC on-board connector
  - LVDS interface with up to four differential data pairs (through parallel-to-LVDS transceiver)
  - 8-bit parallel camera
  - Audio CODEC with the following functionality
    - One 3.5 mm headphone jack
    - One 3.5 mm microphone jack
    - Two speaker outputs
    - One line-out output
    - Two line-in inputs

- Storage
  - microSD card slot
- Communication
  - RS-232
  - RS-485
  - Two CAN FD
  - One Gigabit Ethernet with RJ-45 connector
  - Two USB Host 2.0 interfaces through a stacked USB A type connector
  - USB OTG with AB-type micro-USB connector
  - SISO IEEE 802.11 a/b/g/n/ac + Bluetooth 5.0 with on-module U.FL or external SMA antenna connector
  - PCI Express Mini Card slot supporting full and half-size cards
  - MikroBus socket
  - XBee socket supporting XBee Cellular
- User interface
  - Three user LED, two of them shared with user buttons
- Dimensions:
  - 120 x 160 mm

## Safety instructions

- The ConnectCore MP15 Development Board cannot be guaranteed operation due to the radio link and so should not be used for interlocks in safety critical devices such as machines or automotive applications.
- The ConnectCore MP15 Development Board has not been approved for use in (this list is not exhaustive):
  - nuclear applications
  - explosive or flammable atmospheres
- There are no user serviceable components inside the ConnectCore MP15 Development Board. Do not modify the ConnectCore MP15 in any way. Modifications may exclude the Development Board from any warranty and can cause the ConnectCore MP15 to operate outside of regulatory compliance for a given country, leading to the possible illegal operation of the radio.
- Use industry standard ESD protection when handling the ConnectCore MP15 Development Board.
- Take care while handling to avoid electrical damage to the PCB and components.
- Do not expose ConnectCore MP15 Development Board to water or moisture.
- Use this product with the antennas specified in the ConnectCore MP15 Development Board user guides.

## ESD

The ConnectCore MP15 Development Board has no additional ESD protection added to USB Host (J24) and microSD card (J13) ports. For this reason, ESD stickers have been added to the corresponding

connectors. Please consider this when using the ConnectCore MP15 Development Board. Additional ESD protection shall be added to end products using these interfaces of ConnectCore MP15 SOM.

### Block diagram

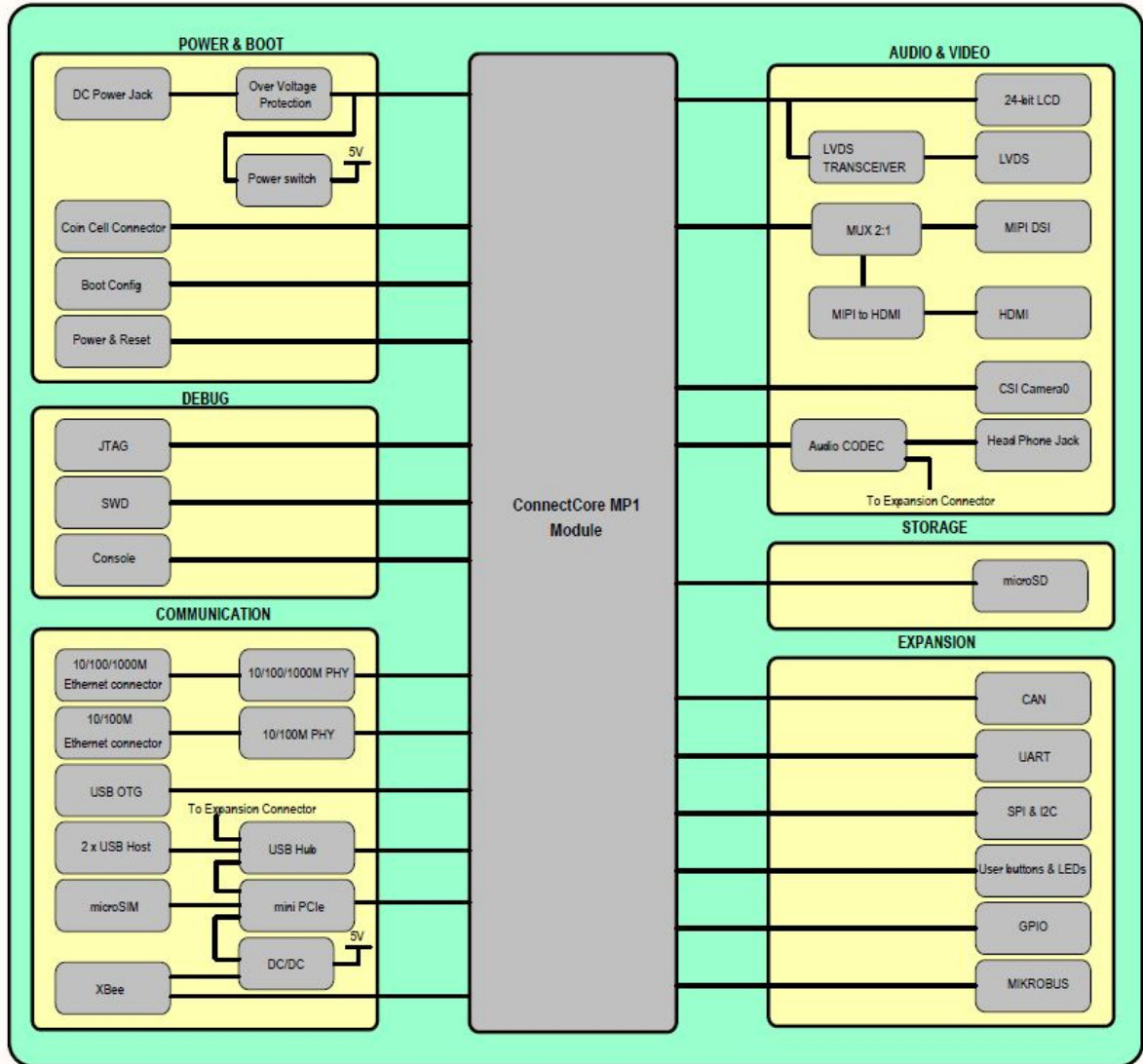

# Placement

## Top view

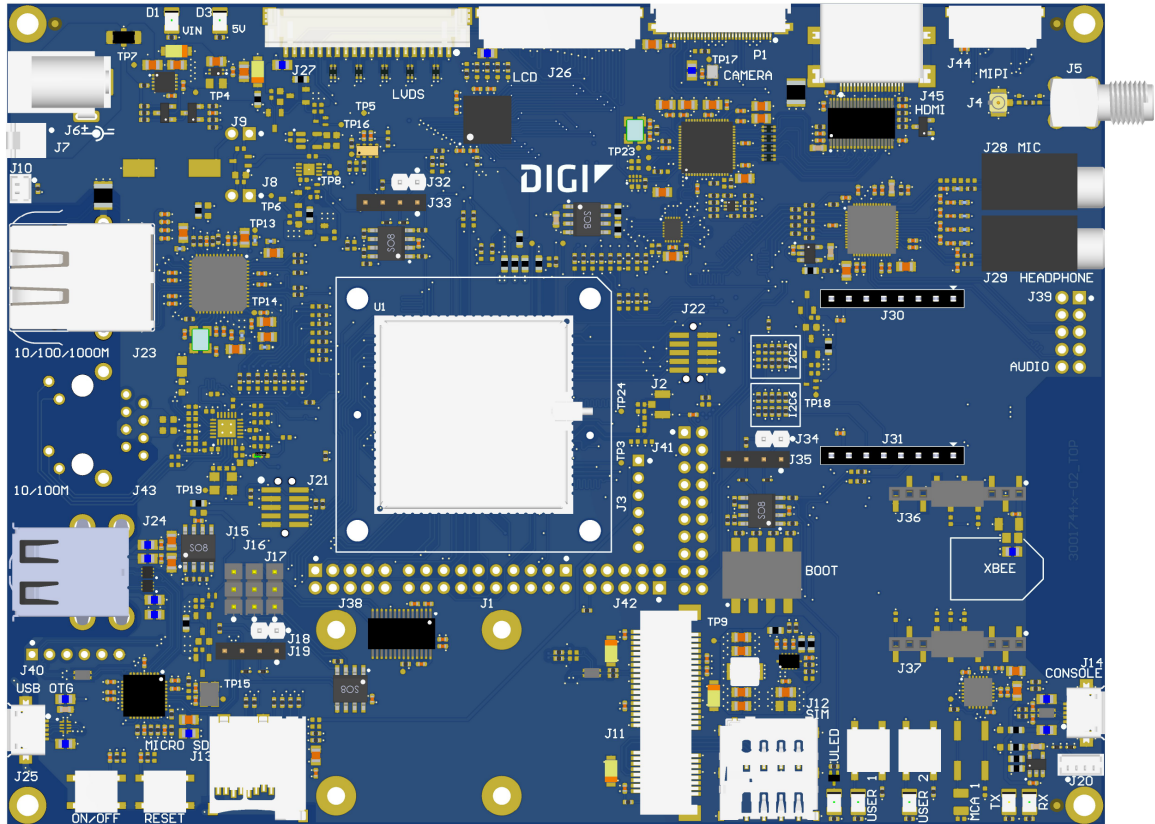

### Bottom view

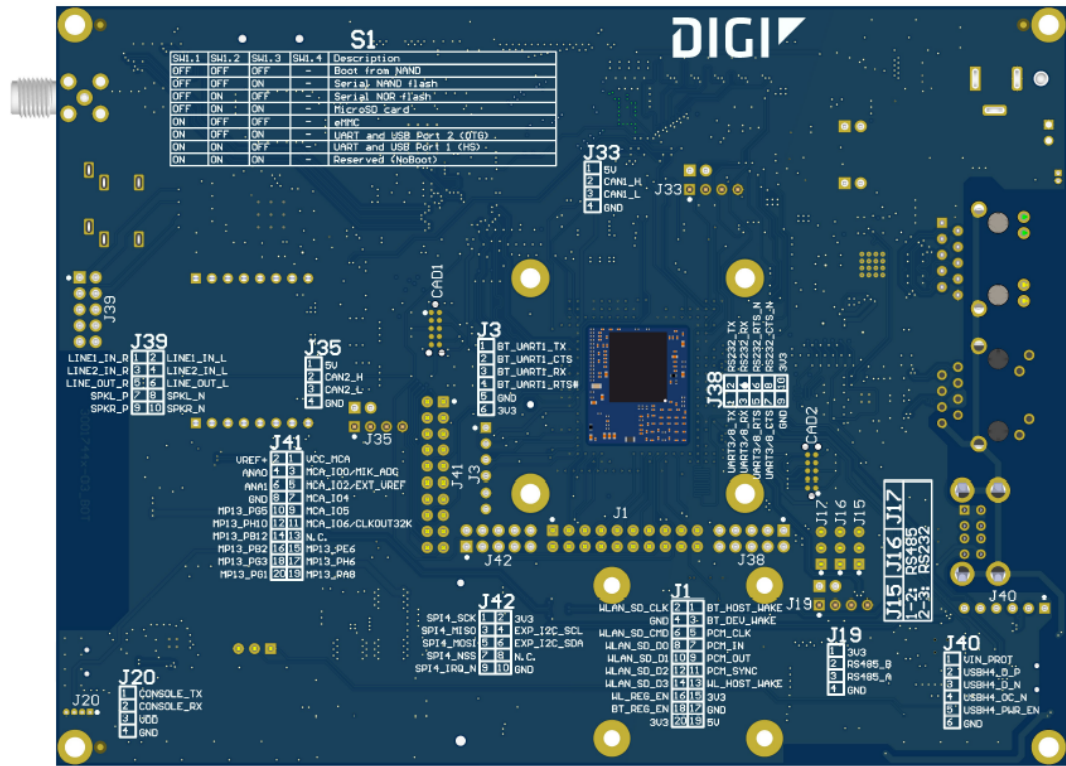

### Connectors

The following table lists all connectors on the ConnectCore MP15:

Connector	Interface
J1	WLAN/Bluetooth expansion
J2	u.FL
J3	Bluetooth UART
J4	u.FL
J5	SMA
J6	5V power-in jack
J7	5V power in
J8	VCC_MCA series jumper
J9	Supercap series jumper

Connector	Interface
J10	Coin cell
J11	Mini PCIe
J12	Micro SIM
J13	microSD
J14	USB Console
J15	RS232/RS485 TX line selector jumper
J16	RS232/RS485 RX line selector jumper
J17	RS232/RS485 RTS line selector jumper
J18	RS485 termination resistor jumper
J19	RS485
J20	TTL Console
J21	STM32MP1 JTAG
J22	MCA SWD
J23	10/100/1000 Mbps RJ-45
J24	Dual USB A-type
J25	USB OTG
J28	Microphone jack
J29	Headphone jack
J30-J31	MikroBus socket
J32	CAN1 termination resistor jumper
J33	CAN1
J36-J37	XBee socket
J38	UART/RS232 expansion
J39	Audio expansion
J40	USB expansion
J41	GPIO expansion
J42	SPI/I2C expansion
J43	10/100 Mbps RJ-45
S1	Boot switches

Connector	Interface
SW1	Power button
SW2	Reset button
SW3	User button
SW4	User button
SW5	User button
CAD1	MCA SWD Tag Connect
CAD2	STM32MP1 JTAG Tag Connect

# Interfaces

---

The following interfaces are available on the ConnectCore MP15:

## Power interfaces

This section describes the ConnectCore MP15 power interfaces.

### DC-in jack connector

The input voltage of the ConnectCore MP1 Development Board is 5V. This input power supply can be provided from two different connectors:

- DC-in power jack.
- J7, a 2-pin, 2.54 mm pitch connector:

Pin	Signal name	Description
1	VIN	5V power supply
2	GND	

---

**Note** Digi recommends *not* powering both connectors at the same time.

---

An overvoltage circuit protects the board from overvoltage and overcurrent events. Downstream from these input power protections, there are two regulators/switches for powering the carrier board circuitry:

- 5V Load switch (U6): A 5V load switch that controls the power delivery to different interfaces on the carrier board.
- PCIe regulator (U7): A dedicated adjustable regulator for the PCIe socket.

### Coin cell connector

Connector J10 on the board is included for attaching an external coin-cell to the system:

Pin	Signal name	Description
1	VCC_LICELL	Power supply for RTC
2	GND	

## Power and reset buttons

One power button (SW1) and one reset button (SW2) are included on the development board.

## System boot

The ConnectCore MP15 module supports different boot modes (see the [ConnectCore MP15 System-on-Module Hardware Reference Manual](#) for detailed information). All of them are supported on the development board, where a quadruple switch (S1) allows swapping between them:

S1.1	S1.2	S1.3	Boot mode
Open	Open	Open	On-module NAND
Open	Open	Close	Serial NAND flash
Open	Close	Open	Serial NOR flash
Open	Close	Close	MicroSD card
Close	Open	Open	eMMC
Close	Open	Close	UART and USB Port 2
Close	Close	Open	UART and USB Port 1
Close	Close	Close	Reserved

## Debug interfaces

### JTAG

The ConnectCore MP15 Development Board provides a Tag Connect footprint for accessing the STM32MP1 JTAG debug port. Additionally, a standard 10-pin, 1.27 mm pitch connector (J21) is available for accessing the JTAG interface:

Pin	Signal name	Description
1	VDD	3.3V power supply
2	JTMS-SWDIO	Mode select line
3	GND	
4	JTCK-SWCLK	Clock line
5	GND	
6	JTDO-TRACESWO	Data output line
7	NC	
8	JTDI	Data input line
9	GND	
10	NRST	Reset line of the CPU

## Console port

A dedicated USB micro AB-type port (J14) provides access to the console port of the ConnectCore MP1 system-on-module. This USB port is routed directly to the CY7C65211 bridge, which converts the USB bus into TTL level. UART4 is used as the console debug port of the STM32MP1 CPU. This UART can also be accessed directly at TTL level through J20 connector:

Pin	Signal name	Description
1	UART4_TX	UART transmission line
2	UART4_RX	UART receiver line
3	VDD	3.3V power supply
4	GND	

Default console port settings:

- Baud rate: 115200
- Data: 8 bit
- Parity: none
- Stop: 1 bit
- Flow control: none

## Multimedia

### Parallel/LVDS display

The ConnectCore MP15 provides a 24-bit RGB LCD interface available through a 40-pin, 0.5 mm pitch, FFC connector. Backlight control signal, I2C port, and interrupt line for the touch screen panel are available on the LCD connector.

The following table shows the pinout of the parallel display connector (J26):

Pin	Signal name	Description
1	GND	
2	LTDC_B2	Blue 2 data line
3	LTDC_B3	Blue 3 data line
4	LTDC_B4	Blue 4 data line
5	LTDC_B5	Blue 5 data line
6	LTDC_B6	Blue 6 data line
7	LTDC_B7	Blue 7 data line
8	LTDC_G2	Green 2 data line

Pin	Signal name	Description
9	LTDC_G3	Green 3 data line
10	LTDC_G4	Green 4 data line
11	LTDC_G5	Green 5 data line
12	LTDC_G6	Green 6 data line
13	LTDC_G7	Green 7 data line
14	LTDC_R2	Red 2 data line
15	LTDC_R3	Red 3 data line
16	LTDC_R4	Red 4 data line
17	LTDC_R5	Red 5 data line
18	LTDC_R6	Red 6 data line
19	LTDC_R7	Red 7 data line
20	LTDC_B0	Blue 0 data line
21	LTDC_B1	Blue 1 data line
22	LTDC_G0	Green 0 data line
23	LTDC_G1	Green 1 data line
24	LTDC_R0	Red 0 data line
25	LTDC_R1	Red 1 data line
26	GND	
27	LTDC_CLK	Display clock line
28	GND	
29	LTDC__HSYNC	Horizontal sync line
30	LTDC__VSYNC	Vertical sync line
31	LTDC_DE	
32	LTDC__RESET	
33	LTDC_I2C_SCL	STM32MP1 I2C2 bus clock line
34	LTDC_I2C_SDA	STM32MP1 I2C2 bus data line
35	LTDC_IRQ_N	Interrupt line
36	GND	
37	BCKL_PWM	Backlight PWM

Pin	Signal name	Description
38	3V3	3.3V power supply
39	5V_DISPLAY	5V power supply
40	5V_DISPLAY	5V power supply

This same parallel display bus is connected to a parallel-to-LVDS transceiver, allowing support for LVDS displays through a 20-pin, 1.25 mm pitch connector (J27). This means that parallel and LVDS connectors cannot be used simultaneously.

This LVDS connector also provides backlight control signal, I2C port, and an interrupt line for the touch screen panel:

Pin	Signal name	Description
1	3V3	3.3V power supply
2	LVDS0_TX0_N	Transmission pair data line 0 (-)
3	LVDS0_TX0_P	Transmission pair data line0 (+)
4	GND	
5	LVDS0_TX1_N	Transmission pair data line 1 (-)
6	LVDS0_TX1_P	Transmission pair data line 1 (+)
7	GND	
8	LVDS0_TX2_N	Transmission pair data line 2 (-)
9	LVDS0_TX2_P	Transmission pair data line 2 (+)
10	GND	
11	LVDS0_CLK_N	Transmission pair clock line (-)
12	LVDS0_CLK_P	Transmission pair clock line (+)
13	GND	
14	LVDS0_TX3_N	Transmission pair data line 3 (-)
15	LVDS0_TX3_P	Transmission pair data line 3 (+)
16	BCKL_PWM	Backlight PWM
17	LTDC_I2C_SCL	STM32MP1 I2C2 bus clock line
18	LTDC_I2C_SDA	STM32MP1 I2C2 bus data line
19	LCD_IRQ_N	Interrupt line
20	5V_DISPLAY	5V power supply

### MIPI/HDMI display

The ConnectCore MP15 system-on-module supports only one MIPI-DSI display interface. On the development board, this MIPI-DSI display is managed so that two different display interfaces are

supported, although only one of them can work at a time:

- HDMI: The Lontium LT8912B bridge is populated on the development board to adapt the MIPI-DSI interface to HDMI. This HDMI interface is available over a standard HDMI connector.
- MIPI-DSI: the native MIPI-DSI interface of the SOM is available over a 20-pin connector (J44):

Pin	Signal name	Description
1	DSI_DA0_P	Data pair 0 (+) line
2	DSI_DA0_N	Data pair 0 (-) line
3	GND	
4	DSI_DA1_P	Data pair 1 (+) line
5	DSI_DA1_N	Data pair 1 (-) line
6	GND	
7	NC	
8	NC	
9	GND	
10	NC	
11	NC	
12	GND	
13	DSI_CKA_P	Clock pair (+) line
14	DSI_CKA_N	Clock pair (-) line
15	GND	
16	LTDC_I2C_SCL	STM32MP1 I2C2 bus clock line
17	LTDC_I2C_SDA	STM32MP1 I2C2 bus data line
18	BCKL_PWM	Backlight PWM
19	GND	
20	3V3	3.3V power supply

### Parallel camera

The ConnectCore MP15 Development Board provides a parallel camera sensor interface (CSI), available over a 30-pin, 0.5 mm pitch FFC connector (P1):

Pin	Signal name	Description
1	GND	
2	NC	

Pin	Signal name	Description
3	NC	
4	DCMI_D0	Camera data line 0
5	DCMI_D1	Camera data line 1
6	DCMI_D2	Camera data line 2
7	DCMI_D3	Camera data line 3
8	DCMI_D4	Camera data line 4
9	DCMI_D5	Camera data line 5
10	DCMI_D6/FDCAN1/2_RX	Camera data line 6
11	DCMI_D7/FDCAN1/2_TX	Camera data line 7
12	NC	
13	NC	
14	GND	
15	DCMI_PIXCLK	Camera pixel clock line
16	GND	
17	DCMI_HSYNC	Camera horizontal sync
18	5V	5V power supply
19	DCMI_VSYNC	Camera vertical sync
20	3V3	3.3V power supply
21	CAMERA_CLK	Camera master clock line
22	NC	
23	GND	
24	NC	
25	CAM_GPIO	Camera dedicated GPIO
26	CAM_PWDN	Camera power down line
27	DCMI_I2C_SDA	STM32MP1 I2C2 bus dataline
28	DCMI_I2C_SCL	STM32MP1 I2C2 bus clock line
29	GND	
30	3V3	3.3V power supply

### Audio

The Maxim MAX98089 audio codec manages the audio interface on the development board. The board provides the following audio functionality:

- 3.5 mm headphone jack
- 3.5 mm microphone jack
- x2 speaker outputs (left and right)
- x1 line-out output
- x2 line-in inputs

The speakers, line-out signals and line-in signals are available over a 10-pin connector (J39):

Pin	Signal name	Description
1	LINE1_IN_R	Single-ended line input A1
2	LINE1_IN_L	Single-ended line input A2
3	LINE2_IN_R	Single-ended line input B1
4	LINE2_IN_L	Single-ended line input B2
5	LINE_OUT_R	Right line output
6	LINE_OUT_L	Left line output
7	SPKL_P	Positive left-channel class D speaker output
8	SPKL_N	Negative left-channel class D speaker output
9	SPKR_P	Positive right-channel class D speaker output
10	SPKR_N	Negative right-channel class D speaker output

## Storage interface

### MicroSD

A microSD socket connected to the SDMMC2 port of the STM32MP1 CPU is available on the ConnectCore MP15.

## Communication

### Gigabit Ethernet

10Base-T/100Base-Tx/1000Base-T Ethernet interface is fully integrated in the board through the Marvell 88E1512 Ethernet PHY. The Ethernet interface is accessible through a RJ-45 connector with integrated link/activity LEDs.

### UART/RS-232/RS-485

RS-232 and RS-485 standards are supported on the ConnectCore MP15 Development Board, by sharing one CPU UART port (UART7). This means that only one of the two protocols can be used at a time. Selection between both is done through three three-position headers (J15, J16 and J17).

RS-232 port is available in connector J38, where USART3 is also connected:

Pin	Signal name	Description
1	USART3/8_TX	UART3 transmission line
2	RS232_7_TX	RS232 transmission line
3	USART3/8_RX	UART3 receiver line
4	RS232_7_RX	RS232 receiver line
5	USART3/8_RTS	UART3 RTS line (output)
6	RS232_7_RTS_N	RS232 RTS line (output)
7	USART3/8_CTS	UART3 CTS line (input)
8	RS232_7_CTS_N	RS232 CTS line (input)
9	GND	
10	3V3	3.3V power supply

---

**Note** USART3 interface is shared with XBee socket and CAN.

---

RS-485 is on J19:

Pin	Signal name	Description
1	3V3	3.3V power supply
2	RS485_B	RS485 B line
3	RS485_A	RS485 A line
4	GND	

You can connect a 120Ω termination resistor to the port by closing J18.

## CAN

Two CAN FD buses are available on the development board through connectors J33 (CAN1) and J35 (CAN2). The pinout of these connectors is as follows, where x refers to the CAN interface on each connector:

Pin	Signal name	Description
1	5V	5V power supply
2	CANx_H	CAN high line
3	CANx_L	CAN low line
4	GND	

You can connect a 120Ω termination resistor to each port by closing J32 (CAN1) and J34 (CAN2).

## USB Host

The ConnectCore MP15 Development Board offers support for four USB Host interfaces. Two of them are available over a stackable dual USB A-type connector. The third USB Host is connected to the PCI Express Mini card connector. The fourth is connected to the XBee socket as well as to a 6-pin, 1.25 mm pitch expansion connector (J40). All USB Hosts can operate at low-speed, full-speed and hi-speed.

The following table shows the pinout of the USB expansion connector:

Pin	Signal name	Description
1	VIN_PROT	5V power supply
2	USBH4_D_P	USB 4 differential data signal (+)
3	USBH4_D_N	USB 4 differential data signal (-)
4	USBH4_OC_N	Over current input
5	USBH4_PWR_EN	Power enable output
6	GND	

## USB OTG

A micro-AB type receptacle for USB OTG connection is available on the ConnectCore MP15 Development Board. This interface can operate in both Host and Device mode.

High-speed, full-speed, and low-speed connections are supported in Host mode. High-speed and full-speed connections are supported in Device mode.

---

Do not connect the USB OTG port of the ConnectCore MP15 Development Board to a downstream port (e.g a host PC) if the main power of the board is removed. This could cause permanent damage to the system. Refer to the [ConnectCore MP15 System-on-Module Hardware Reference Manual](#) and the application note AN4879 from ST for more information.

This issue is fixed as of PCB version 30017442-04. You can find the version number printed on both the top and bottom of the PCB.

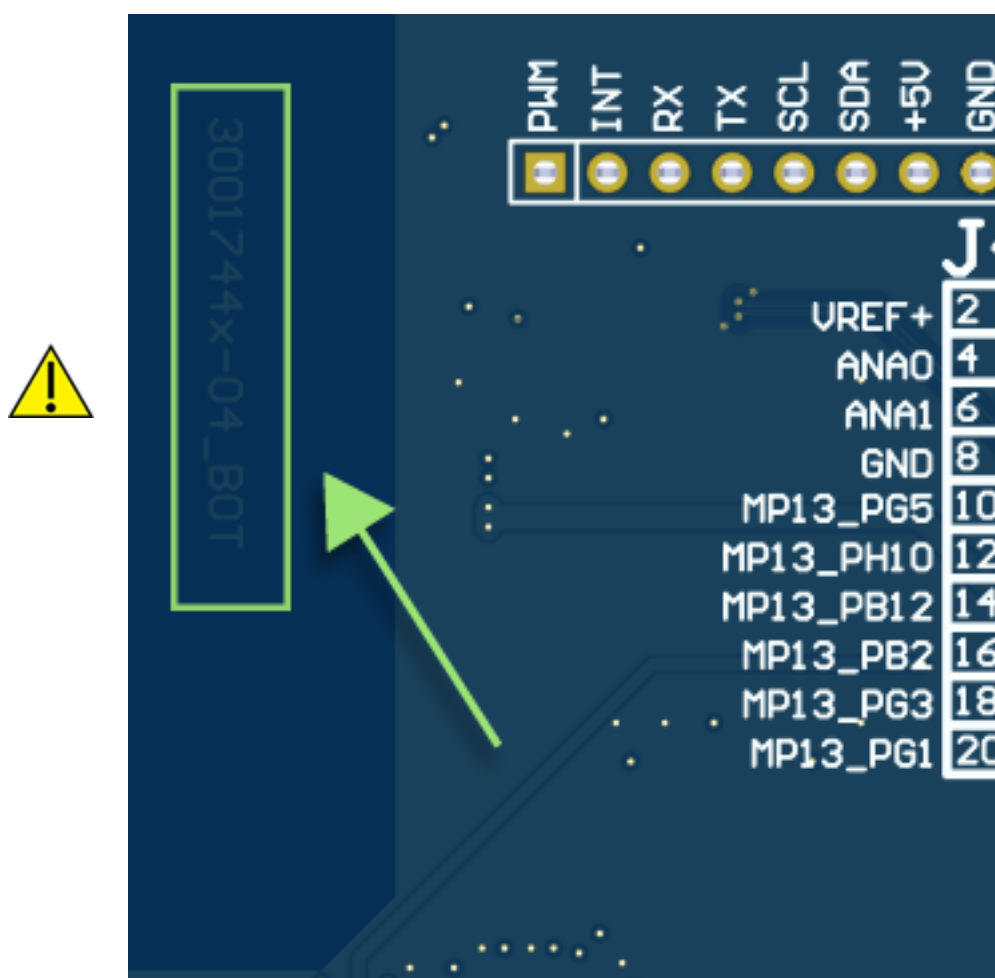

## Mini PCI Express slot

The ConnectCore MP15 Development Board provides a Mini PCI Express socket supporting USB and I2C connection to the ConnectCore MP15 module. A micro SIM socket is also connected to the Mini PCI Express slot.

## XBee socket

One XBee socket is populated on the development board, supporting XBee Cellular modules. The UART bus connected to the XBee socket (USART3) is shared with CAN2.

## MikroBus socket

The ConnectCore MP15 Development Board provides a socket compatible with MikroElektronika MikroBus click boards, supporting I2C, UART, SPI, ADC and PWM connectivity.

## SPI and I2C

A expansion connector provides access to one SPI interface (shared with the MikroBus socket) and the I2C2 bus:

Pin	Signal name	Description
1	SPI4_SCK	SPI clock line
2	3V3	3.3V power supply
3	SPI4_MISO	SPI MISO line
4	EXP_I2C_SCL	STM32MP1 I2C2 bus clock line
5	SPI4_MOSI	SPI MOSI line
6	EXP_I2C_SDA	STM32MP1 I2C2 bus data line
7	SPI4_NSS	SPI slave select line
8	NC	
9	SPI1_IRQ_N	Interrupt line/GPIO
10	GND	

## GPIO

An additional expansion connector provides access to different IOs for general purpose usage:

Pin	Signal name	Description
1	VCC_MCA	MCA power supply
2	VREF+	STM32MP1 internal ADC/DAC reference voltage
3	MCA_IO0/MIK_ADC	MCA IO

Pin	Signal name	Description
4	ANA0	STM32MP1 ADC
5	MCA_IO2/EXT_VREF	MCA IO
6	ANA1	STM32MP1 ADC
7	MCA_IO4	MCA IO
8	GND	
9	MCA_IO5	MCA IO
10	NU	Not used on MP15
11	MCA_IO6/CLKOUT32K	MCA IO and 32 kHz output clock
12	NU	Not used on MP15
13	MP15_PF15	STM32MP1 IO
14	NU	Not used on MP15
15	NU	Not used on MP15
16	NU	Not used on MP15
17	NU	Not used on MP15
18	NU	Not used on MP15
19	NU	Not used on MP15
20	NU	Not used on MP15

## User interfaces

Three LEDs are available on the development board, all of them are connected to CPU GPIOs. Two of them are shared with user buttons.

## Wireless

There is a u.FL connector (J4) which is routed directly to a SMA connector (J5). The purpose is to adapt the u.FL form factor to the SMA form factor to extend the number of antennas that can be used on the development board for either the on-module antenna path or any other RF path that could be used on a PCIe or XBee board.

# Specifications

---

## Electrical specification

### Supply voltages

The ConnectCore MP15 Development Board has one primary supply input, VIN, which powers both the ConnectCore MP15 Development Board and the ConnectCore MP15 system-on-module. An additional input supply powers the RTC of development board when the main supply is not present.

The following table shows the voltage range of the input supplies of the ConnectCore MP15 Development Board:

Signal	Description	Min	Typ	Max	Unit
VIN	Power jack input	4.6	5.0	5.5	V
VCC_LICELL	Supply for RTC	1.1		5.5	V

## Mechanical specification

The ConnectCore MP15 Development Board dimensions are 120 x 160 mm. Four 3.2 mm drills are located on the four corners of the PCB for assembling the board into an enclosure. These drills have a 5.5 mm round metalized area for the screws and nuts. The board has four 2.6 mm drills to assemble a half-size or full-size PCI express mini card module, with 5.8 mm x 5.8 mm square metalized area for the screws and nuts.

## Environmental specification

Specification	Operating temperature
Industrial	-40° C to +85° C

## WLAN specification

For a complete WLAN specification, refer to the [ConnectCore MP15 System-on-Module Hardware Reference Manual](#).